

Fuel Pump Wiring Schematic – Integrated with G3X

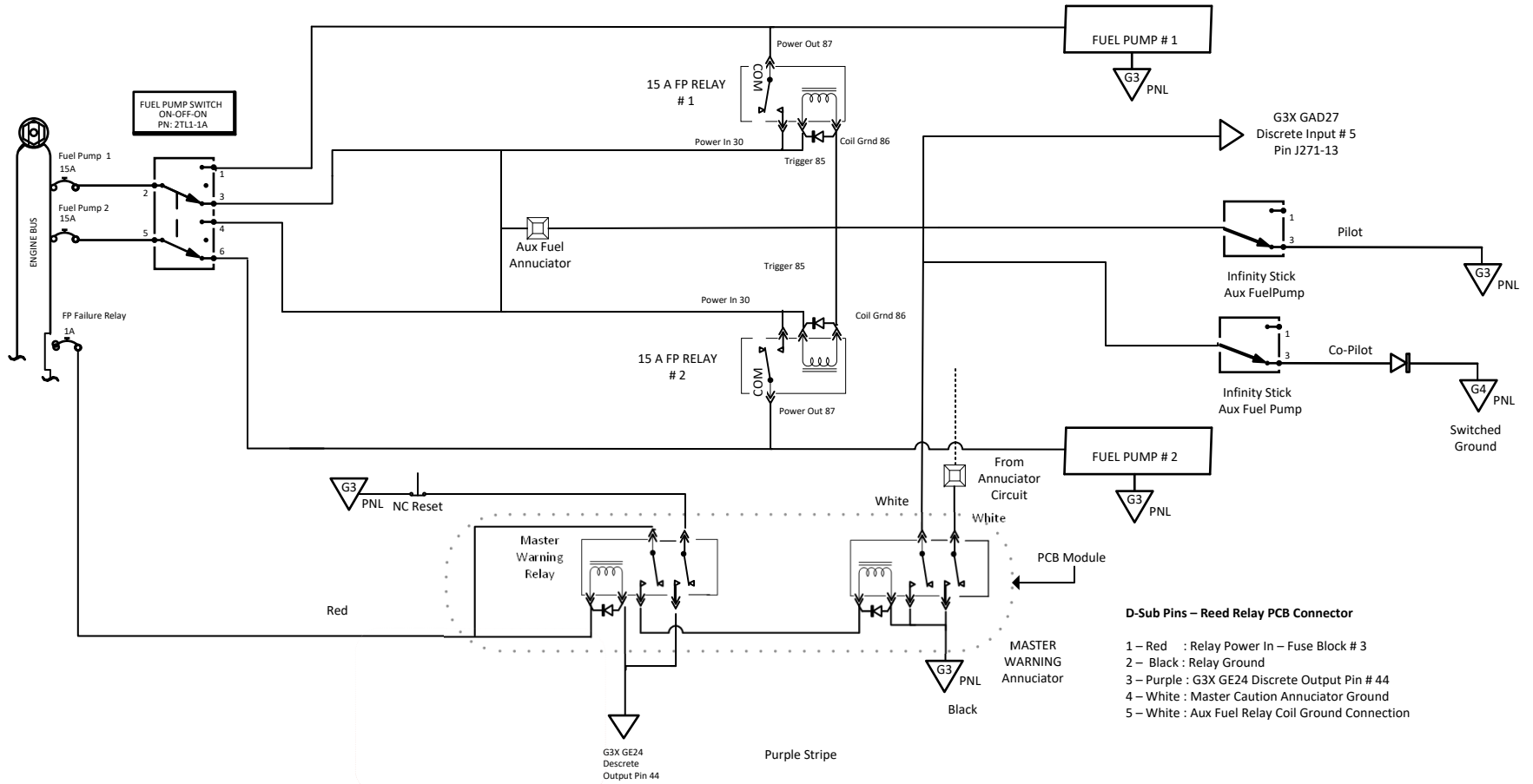

Notes :

- FP Relays : TE Connectivity Part # 1432772-1 / Digikey PB685-ND
- Master Warning Relay 1 (DPST) : Littlefuse Inc Part # HE722A1210 / Digikey HE109-ND
- Master Warning Relay 2 (DPST): Littlefuse Inc Part # HE722A1210 / Digikey HE109-ND
- Littlefuse relays have integral diodes
- TE Connectivity Power Relays are wired with Perhelion Design bi-direction zener diodes

Title					C-GROK – G3X Fuel Pumps				
Author					Les Kearney				
Path					H:\RV10\GROK\Electrical\Wiring\ESysV70.vsd				
Version	7.0	Date	2021 Mar 31	3-G3X & FUEL					